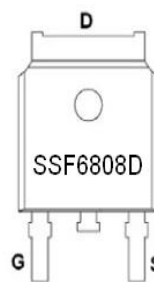
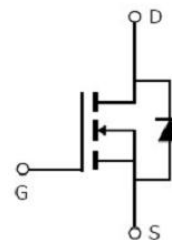

Main Product Characteristics:

V_{DSS}	68V
$R_{DS(on)}$	6.1mohm(typ.)
I_D	79A

DPAK

Marking and pin Assignment

Schematic diagram
Features and Benefits:

- Advanced trench MOSFET process technology
- Special designed for PWM, load switching and general purpose applications
- Ultra low on-resistance with low gate charge
- Fast switching and reverse body recovery
- 175°C operating temperature

Description:

It utilizes the latest trench processing techniques to achieve the high cell density and reduces the on-resistance with high repetitive avalanche rating. These features combine to make this design an extremely efficient and reliable device for use in power switching application and a wide variety of other applications

Absolute max Rating:

Symbol	Parameter	Max.	Units
$I_D @ TC = 25^\circ C$	Continuous Drain Current, $V_{GS} @ 10V$ ①	79	A
$I_D @ TC = 100^\circ C$	Continuous Drain Current, $V_{GS} @ 10V$ ①	56	
I_{DM}	Pulsed Drain Current②	316	
$P_D @ TC = 25^\circ C$	Power Dissipation③	114	W
	Linear Derating Factor	0.76	W/°C
V_{DS}	Drain-Source Voltage	68	V
V_{GS}	Gate-to-Source Voltage	± 20	V
E_{AS}	Single Pulse Avalanche Energy @ L=0.3mH	252	mJ
I_{AS}	Avalanche Current @ L=0.3mH	41	A
T_J T_{STG}	Operating Junction and Storage Temperature Range	-55 to + 175	°C

Thermal Resistance

Symbol	Characterizes	Typ.	Max.	Units
R _{θJC}	Junction-to-case ^③	—	1.32	°C/W
R _{θJA}	Junction-to-ambient (t ≤ 10s) ^④	—	62	°C/W
	Junction-to-Ambient (PCB mounted, steady-state) ^④	—	40	°C/W

Electrical Characterizes @T_A=25°C unless otherwise specified

Symbol	Parameter	Min.	Typ.	Max.	Units	Conditions
V _{(BR)DSS}	Drain-to-Source breakdown voltage	68	—	—	V	V _{GS} = 0V, I _D = 250μA
R _{DS(on)}	Static Drain-to-Source on-resistance	—	6.5	8	mΩ	V _{GS} =10V, I _D = 30A T _J = 125°C
		—	11.1	—		
V _{GS(th)}	Gate threshold voltage	2	—	4	V	V _{DS} = V _{GS} , I _D = 250μA T _J = 125°C
		—	2.3	—		
I _{DSS}	Drain-to-Source leakage current	—	—	1	μA	V _{DS} = 68V, V _{GS} = 0V T _J = 125°C
		—	—	50		
I _{GSS}	Gate-to-Source forward leakage	—	—	100	nA	V _{GS} = 20V V _{GS} = -20V
		-100	—	—		
Q _g	Total gate charge	—	74.6	—	nC	I _D = 50A, V _{DS} =48V, V _{GS} = 10V
Q _{gs}	Gate-to-Source charge	—	19.2	—		
Q _{gd}	Gate-to-Drain("Miller") charge	—	27.9	—		
t _{d(on)}	Turn-on delay time	—	16.0	—	ns	V _{GS} =10V, V _{DS} =60V, R _L =1Ω, R _{GEN} =2.55Ω I _D =60A
t _r	Rise time	—	96.4	—		
t _{d(off)}	Turn-Off delay time	—	38.4	—		
t _f	Fall time	—	95.9	—		
C _{iss}	Input capacitance	—	3627	—	pF	V _{GS} = 0V V _{DS} = 25V f = 1MHz
C _{oss}	Output capacitance	—	391	—		
C _{rss}	Reverse transfer capacitance	—	275	—		

Source-Drain Ratings and Characteristics

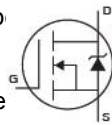
Symbol	Parameter	Min.	Typ.	Max.	Units	Conditions
I _S	Continuous Source Current (Body Diode)	—	—	79	A	MOSFET symb showing the integral reverse p-n junction diode. 
I _{SM}	Pulsed Source Current (Body Diode)	—	—	316	A	
V _{SD}	Diode Forward Voltage	—	0.80	1.3	V	I _S =30A, V _{GS} =0V
t _{rr}	Reverse Recovery Time	—	29.4	—	ns	T _J = 25°C, I _F = 68A, di/dt = 100A/μs
Q _{rr}	Reverse Recovery Charge	—	30.2	—	nC	

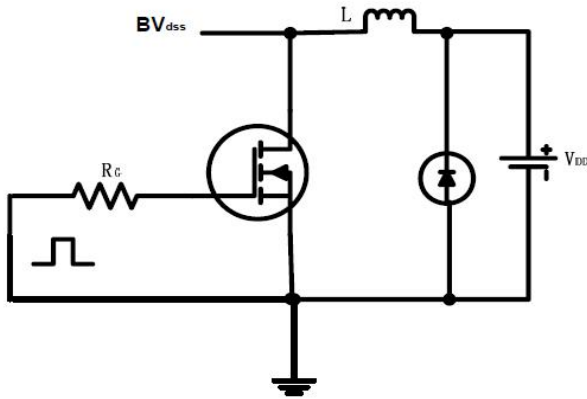
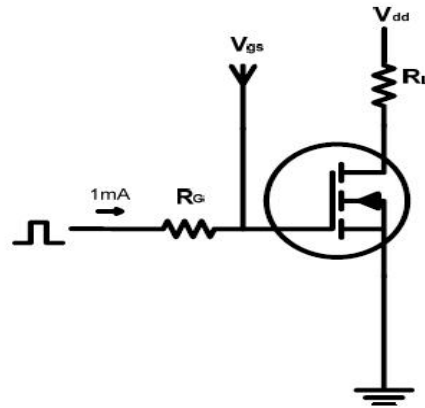
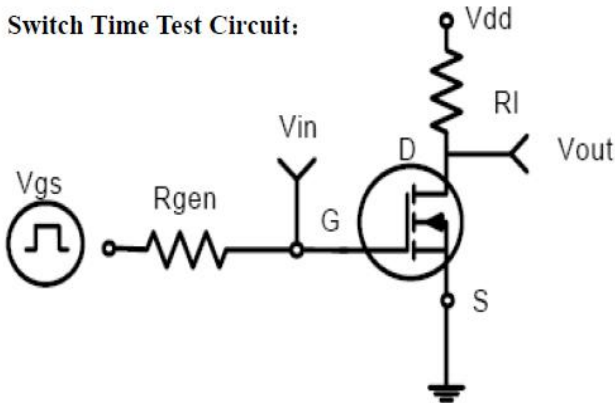
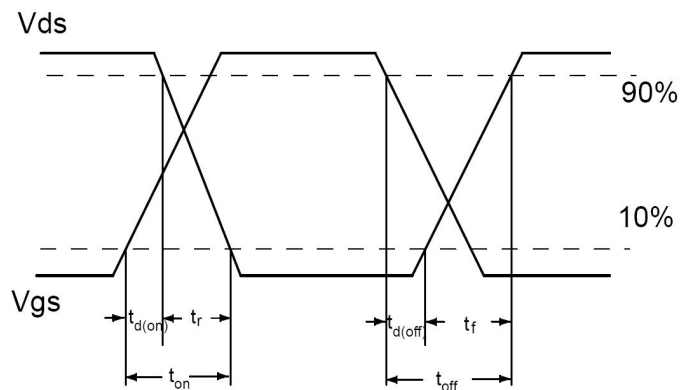
Test circuits and Waveforms
EAS test circuits:

Gate charge test circuit:

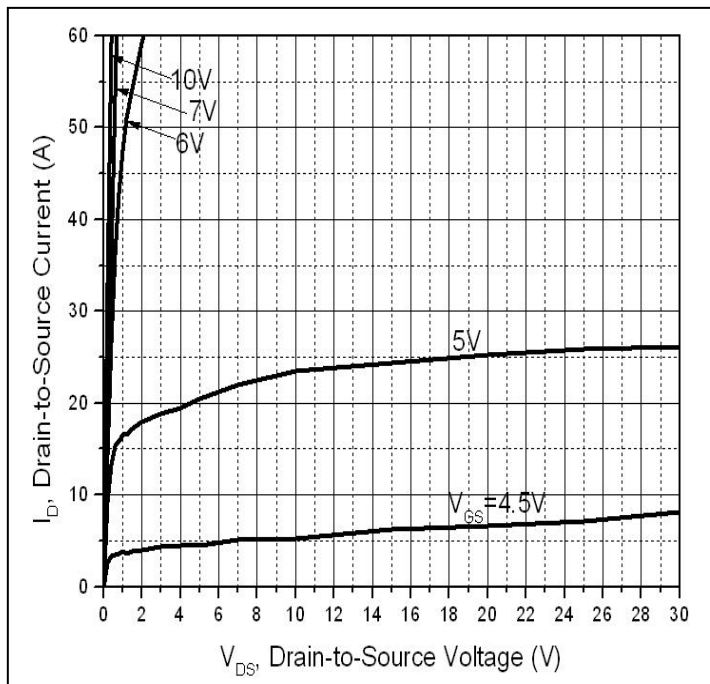
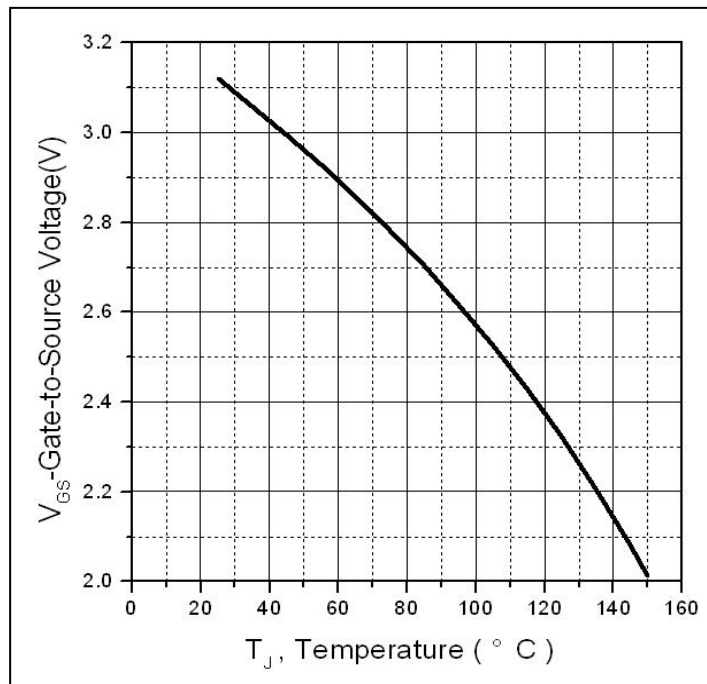
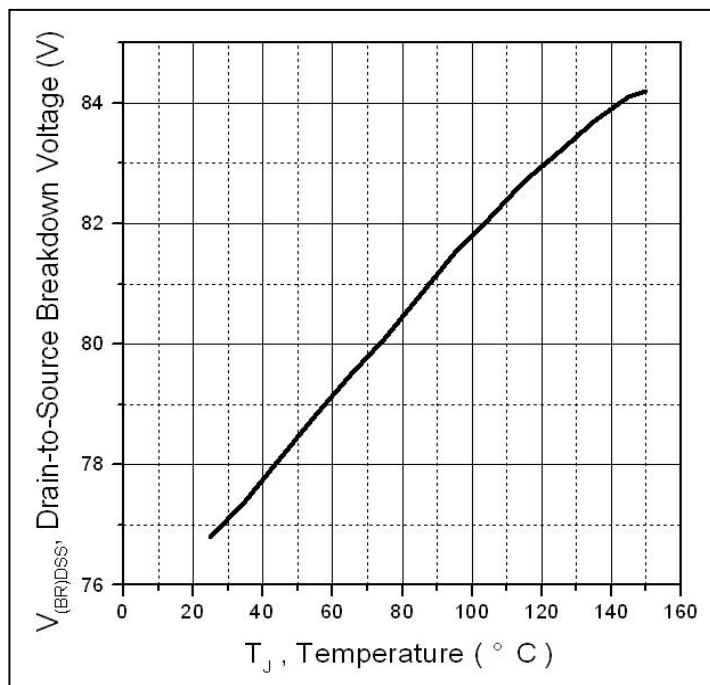
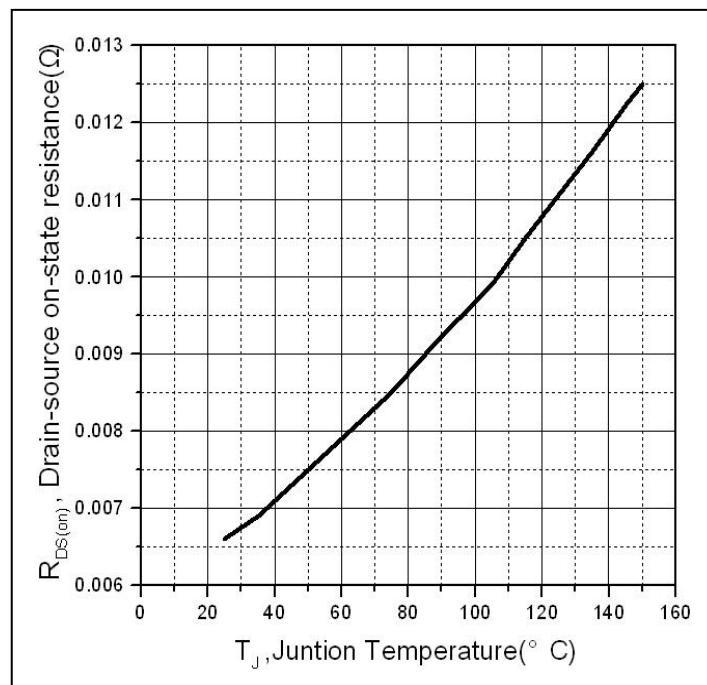
Switch Time Test Circuit:

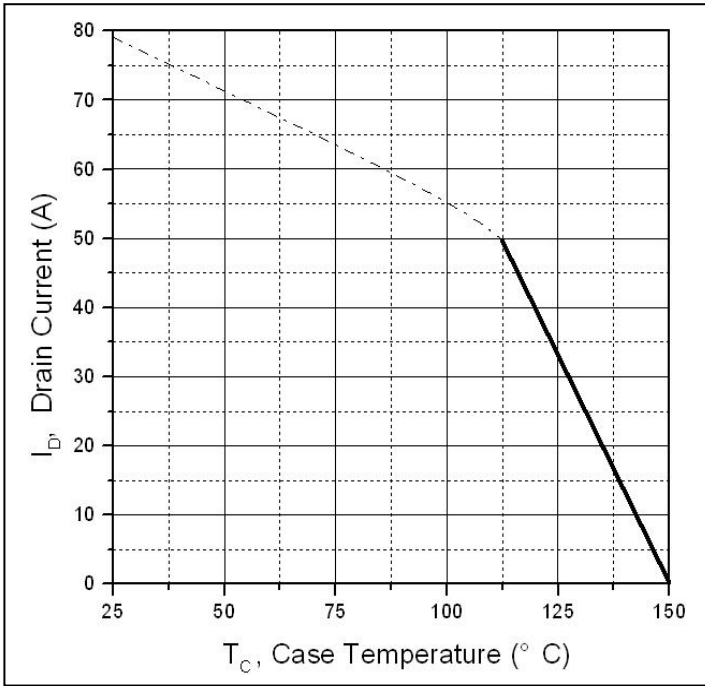
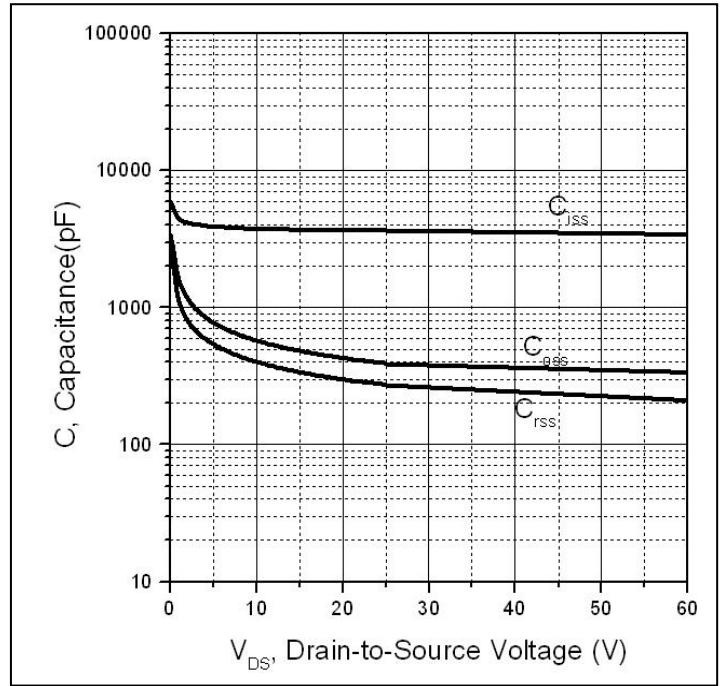
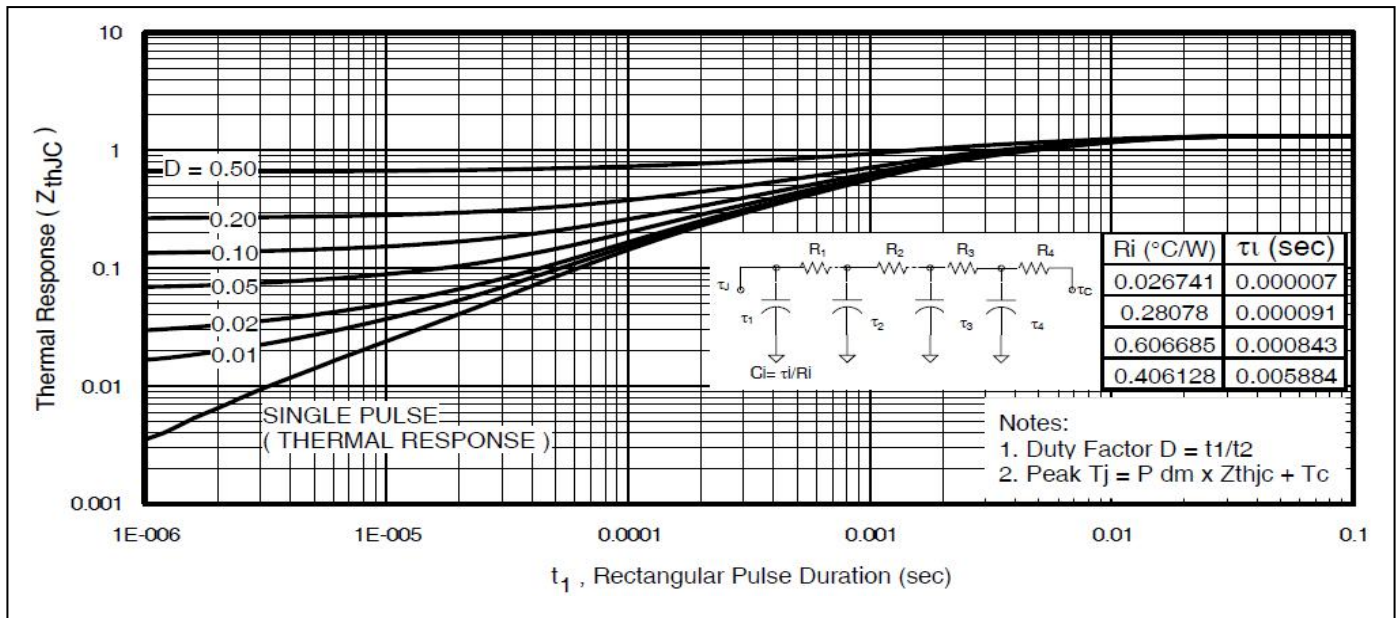
Switch Waveforms:

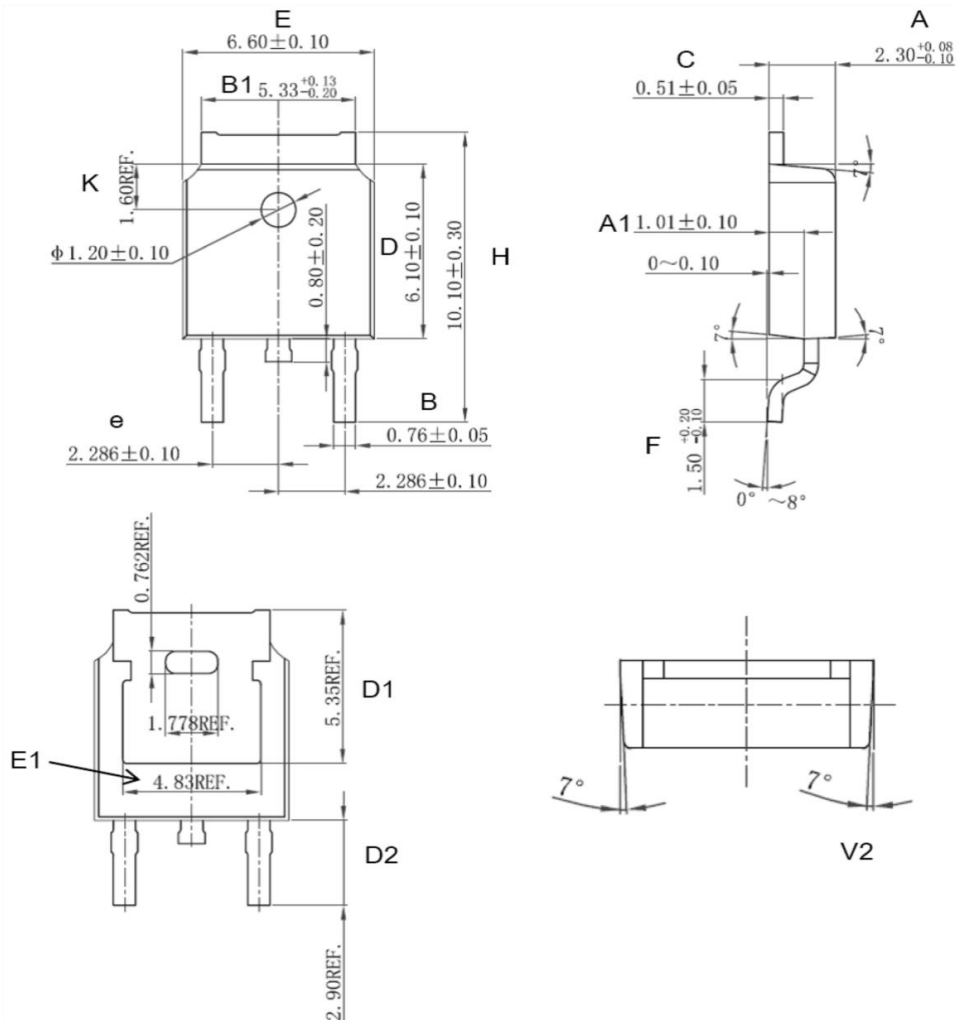
Notes:

- ① The maximum current rating is limited by bond-wires.
- ② Repetitive rating; pulse width limited by max. junction temperature.
- ③ The power dissipation PD is based on max. junction temperature, using junction-to-case thermal resistance.
- ④ The value of $R_{\theta JA}$ is measured with the device mounted on 1in 2 FR-4 board with 2oz. Copper, in a still air environment with $T_A = 25^\circ C$
- ⑤ These curves are based on the junction-to-case thermal impedance which is measured with the device mounted to a large heatsink, assuming a maximum junction temperature of $T_{J(MAX)} = 175^\circ C$.
- ⑥ The maximum current rating is limited by bond-wires.

Typical electrical and thermal characteristics

Figure 1: Typical Output Characteristics

Figure 2. Gate to source cut-off voltage

Figure 3. Drain-to-Source Breakdown Voltage vs. Temperature

Figure 4: Normalized On-Resistance Vs. Case Temperature

Typical electrical and thermal characteristics

Figure 5. Maximum Drain Current Vs. Case Temperature

Figure 6. Typical Capacitance Vs. Drain-to-Source Voltage

Figure 7. Maximum Effective Transient Thermal Impedance, Junction-to-Case

Mechanical Data:
DPAK PACKAGE OUTLINE DIMENSION

Symbol	Dimension In Millimeters			Dimension In Inches		
	Min	Nom	Max	Min	Nom	Max
A	2.200	2.300	2.380	0.087	0.091	0.094
A1	0.910	1.010	1.110	0.036	0.040	0.044
B	0.710	0.760	0.810	0.028	0.030	0.032
B1	5.130	5.330	5.460	0.202	0.210	0.215
C	0.460	0.510	0.560	0.018	0.020	0.022
D	6.000	6.100	6.200	0.236	0.240	0.244
D1	5.350 (REF)			0.211 (REF)		
D2	2.900 (REF)			0.114 (REF)		
E	6.500	6.600	6.700	0.256	0.260	0.264
E1	4.83 (REF)			0.190 (REF)		
e	2.186	2.286	2.386	0.086	0.090	0.094
H	9.800	10.100	10.400	0.386	0.398	0.409
F	1.400	1.500	1.700	0.055	0.059	0.067
K	1.600 (REF)			0.063 (REF)		
V2	8° (REF)			8° (REF)		

Ordering and Marking Information
Device Marking: SSF6808D

Package (Available)
DPAK
Operating Temperature Range
C : -55 to 175 °C

Devices per Unit
Option1:

Package Type	Units/ Tube	Tubes/Inner Box	Units/Inner Box	Inner Boxes/Carton Box	Units/Carton Box
DPAK	80	50	4000	10	40000

Option2:

Package Type	Units/ Tape	Tapes/Inner Box	Units/Inner Box	Inner Boxes/Carton Box	Units/Carton Box
DPAK	2500	1	2500	10	25000

Reliability Test Program

Test Item	Conditions	Duration	Sample Size
High Temperature Reverse Bias(HTRB)	T _j =125°C to 175°C @ 80% of Max V _{DSS} /V _{CES} /VR	168 hours 500 hours 1000 hours	3 lots x 77 devices
High Temperature Gate Bias(HTGB)	T _j =150°C or 175°C @ 100% of Max V _{GSS}	168 hours 500 hours 1000 hours	3 lots x 77 devices

ATTENTION:

- Any and all Silikron products described or contained herein do not have specifications that can handle applications that require extremely high levels of reliability, such as life-support systems, aircraft's control systems, or other applications whose failure can be reasonably expected to result in serious physical and/or material damage. Consult with your Silikron representative nearest you before using any Silikron products described or contained herein in such applications.
- Silikron assumes no responsibility for equipment failures that result from using products at values that exceed, even momentarily, rated values (such as maximum ratings, operating condition ranges, or other parameters) listed in products specifications of any and all Silikron products described or contained herein.
- Specifications of any and all Silikron products described or contained herein stipulate the performance, characteristics, and functions of the described products in the independent state, and are not guarantees of the performance, characteristics, and functions of the described products as mounted in the customer's products or equipment. To verify symptoms and states that cannot be evaluated in an independent device, the customer should always evaluate and test devices mounted in the customer's products or equipment.
- Silikron Semiconductor CO.,LTD. strives to supply high-quality high-reliability products. However, any and all semiconductor products fail with some probability. It is possible that these probabilistic failures could give rise to accidents or events that could endanger human lives, that could give rise to smoke or fire, or that could cause damage to other property. When designing equipment, adopt safety measures so that these kinds of accidents or events cannot occur. Such measures include but are not limited to protective circuits and error prevention circuits for safe design, redundant design, and structural design.
- In the event that any or all Silikron products(including technical data, services) described or contained herein are controlled under any of applicable local export control laws and regulations, such products must not be exported without obtaining the export license from the authorities concerned in accordance with the above law.
- No part of this publication may be reproduced or transmitted in any form or by any means, electronic or mechanical, including photocopying and recording, or any information storage or retrieval system, or otherwise, without the prior written permission of Silikron Semiconductor CO.,LTD.
- Information (including circuit diagrams and circuit parameters) herein is for example only ; it is not guaranteed for volume production. Silikron believes information herein is accurate and reliable, but no guarantees are made or implied regarding its use or any infringements of intellectual property rights or other rights of third parties.
- Any and all information described or contained herein are subject to change without notice due to product/technology improvement, etc. When designing equipment, refer to the "Delivery Specification" for the Silikron product that you intend to use.
- This catalog provides information as of Dec, 2008. Specifications and information herein are subject to change without notice.

Customer Service**Worldwide Sales and Service:**

Sales@silikron.com

Technical Support:

Technical@silikron.com

Suzhou Silikron Semiconductor Corp.



SSF6808D

11A, 428 Xinglong Street, Suzhou Industrial Park, P.R.China

TEL: (86-512) 62560688

FAX: (86-512) 65160705

E-mail: Sales@silikron.com